

Type 2 Half Safety Cage Structure Registration

Original registration document shall remain with the vehicle's Log Book.

Vehicle and Customer Details

The structure outlined below is manufactured for the following vehicle:

MAKE	MODEL
CHASSIS NO.	ESTIMATED VEHICLE WEIGHT
CUSTOMER NAME	CAMS LICENCE NO. (if applicable)

Manufacturer's Details and Declaration

I declare the Safety Cage Structure described on this form was manufactured by me or under my supervision to comply with the material, configuration and mounting requirements of CAMS in force at the time of registration.

NAME OF MANUFACTURER

ADDRESS

SUBURB

STATE

POSTCODE

PHONE

EMAIL

NAME

SIGNATURE

SIGN HERE

COMPLETION DATE OF SAFETY CAGE STRUCTURE - -

Attention: The issue of this document does not signify that the structure has been accepted by CAMS as being in compliance with the requirements for Safety Cages as specified in Schedule J of the CAMS Manual of Motor Sport.

Structure Details

Component	Main Hoop	Backstays	Diagonals	Front Leg
Steel Type				
Outside Diameter	mm	mm	mm	mm
Wall Thickness	mm	mm	mm	mm

METHOD OF ATTACHMENT TO VEHICLE

FULLY WELDED

BOLTED TO WELDED REINFORCEMENTS

BOLTED ONLY

DETAILS OF STRUCTURE

Show the position of all tubes with the basic structure below. For clarity, it is only necessary to show side intrusion bars and braces fitted to one side of the cage unless the other side is different. The position of and type of dismantable joints should be clearly identifiable (eg. circled)

TYPE OF COMPETITION

SPEED	DRIFTING
AUTO TEST	OFF ROAD
RALLY	RACE

HIGHEST LEVEL OF COMPETITION

CLUB

STATE CHAMPIONSHIP

NATIONAL SERIES OR CHAMPIONSHIP

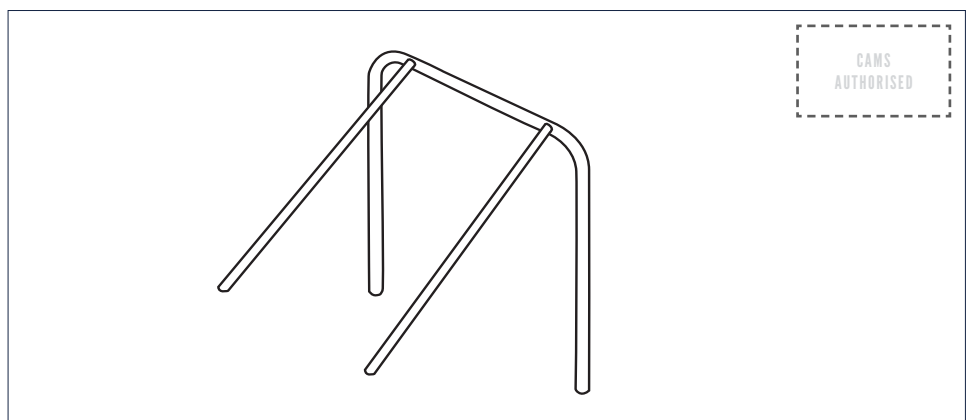

Note: Write the letters NF where members are not fitted as part of the Safety Cage Structure

CAMS USE ONLY

SAFETY CAGE STRUCTURE SERIAL NO.

REGISTRATION ISSUE DATE

LOG BOOK NO.

AUTHORISING OFFICER

VEHICLE ID NO.

SIGNATURE

REMARKS OR RESTRICTIONS

Instructions to Safety Cage Manufacturers and Vehicle Owners

SAFETY CAGE STRUCTURE PICTURES MUST BE SUPPLIED WITH APPLICATION

Safety Cage Registration can be completed once the Safety Cage is installed and prior to a Log Book application.

Note 1: It is the responsibility of the Manufacturer to:

- Read and understand Schedule J of the CAMS Manual of Motor Sport prior to the fabrication of a Safety Cage Structure
- Ensure the accuracy of the information supplied to CAMS

Note 2: This form is to be used only where the safety cage is added to a conventional car body, and is not part of a space frame or tub style chassis.

Note 3: Do not use this form with Certified or Homologated Safety Cage Structures.

Note 4: The issue of this document does not signify that the structure has been accepted by CAMS as being in compliance with the requirements for safety cages as specified in Schedule J of the CAMS Manual of Motor Sport, or the relevant Group Technical Regulations.

Note 5: The use of ERW pipe (to AS 1163), which is not drawn to size by a Cold Finishing Process, is not permitted unless the Safety Cage is Certified by CAMS with an Engineers certification. External dimensions of 42.4mm or 48.3mm normally indicate that the tube is ERW, a Cold Formed, not a Cold Drawn or Finished tube.

Note 6: Chrome Moly is not permitted unless the Safety Cage Structure is Certified by CAMS.

Note 7: If this document is submitted to CAMS without a log book application a postal address must be provided in order for CAMS to return the original document and safety cage structure sticker to the customer/manufacturer.

Note 8: If this safety cage structure is installed in a vehicle which has been log booked by CAMS, the log book is required to be sent to CAMS along with this document for the appropriate amendments to be filled in by a CAMS Officer.

Tube Type: The tubing type is to be shown as one of the following:

- CDS - Cold Drawn Seamless
- CDW - Cold Drawn Welded
- CEW - Cold Drawn Electric Resistance welded.

These descriptions are shown on the Product Sheet which should be obtained from your steel supplier with each batch of tubing you purchase.

Dimensions: These sizes refer to the external diameter of the tube and the wall thickness. They will normally be 44.45mm OD for the main hoop and 38mm OD for all other braces, with wall thickness of 2.5mm or greater. This detail is also shown on the Product Sheet for the tubing.

Drawings: Specify the Type and the highest level of competition applied for.

Using a ruler, show the position of the diagonal(s) and any other additional tubes fitted to the Safety Cage Structure. Supply actual pictures of front and rear aspects of structure (see examples right).

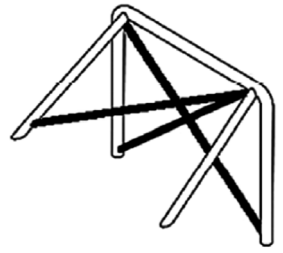

Customer Details

CUSTOMER NAME

CAMS LICENCE NO. (if applicable)

ADDRESS

SUBURB

STATE

POSTCODE

PHONE

EMAIL

Payment

PRE-LOG BOOK SAFETY CAGE REGISTRATION: \$20 (inc. gst)

(If submitted with a Log Book Application the price for Safety Cage Registration will be \$20 and included in the fee for the Log Book)

PAYING BY

(please tick appropriate box)

CASH

(ONLY if paying in person at a CAMS Office)

CHEQUE/MONEY ORDER

(made payable to "Confederation of Australian Motor Sport Limited")

CREDIT CARD

(please complete details)

CARD NUMBER

EXPIRY

/

CVV

CARD TYPE

VISA

MASTERCARD

NAME ON CARD

SIGNED

SIGN HERE

**PLEASE SUBMIT THIS DOCUMENT AND LOG BOOK (IF APPLICABLE) TO:
CAMS TECHNICAL DEPARTMENT
P.O. BOX 147, CAULFIELD EAST, VIC, 3145
OR EMAIL THIS DOCUMENT TO: LOGBOOKS@CAMS.COM.AU**